

P/N 93080048 PLD7M CLASS 2 OUTPUT
P/N 93081950 PLD7M2

PLD7M/M2

Emergency LED Battery Pack Installation,
Operation, and Service Instructions

IMPORTANT SAFEGUARDS

When using electrical equipment, basic safety precautions should always be followed including the following.

READ AND FOLLOW ALL SAFETY INSTRUCTIONS

1. Do not join converter connection until installation is complete and AC power is supplied to the emergency driver.
2. This product is for use with an emergency LED lighting load and supplies 7.0 W of constant output power to LED lamps rated from 15-56 Vdc. Operates emergency LED load in the emergency mode for a minimum of 90 minutes.
3. Make sure all connections are in accordance with the NEC and any local regulations.
4. To reduce the risk of electric shock, disconnect both normal and emergency power supplies and converter connector from the emergency driver before servicing.
5. This emergency driver is suitable for factory or field installation inside a suitable lighting fixture.
6. Do not use outdoors. This product is suitable for use in damp locations where the ambient temperature is 0°C minimum, +55°C maximum. Product is not suitable for heated air outlets and wet or hazardous locations.
7. An unswitched AC power source is required (120-277 VAC, 50/60 Hz).
8. Do not install near gas or electric heaters.
9. Do not attempt to service the battery. A sealed, no-maintenance battery is used that is not field replaceable. Contact Dual-Lite for information on service.
10. The use of accessory equipment not recommended by the manufacturer may cause an unsafe condition.
11. Do not use this product for other than intended use.
12. Servicing should be performed by a qualified service personnel.
13. Equipment should be mounted in locations and at heights where it will not be subjected to tampering by unauthorized personnel

SAVE THESE INSTRUCTIONS

WARNING - This product contains chemicals known to the State of California to cause cancer, birth defects, and/or other reproductive harm. Thoroughly wash hands after installing, cleaning, or otherwise touching this product.

This equipment has been tested and found to comply with the limits for a Class A digital device, pursuant to part 15 of the FCC Rules. These limits are designed to provide reasonable protection against harmful interference when the equipment is operated in a commercial environment. This equipment generates, uses, and can radiate radio frequency energy and, if not installed and used in accordance with the instruction manual, may cause harmful interference to radio communications. Operation of this equipment in a residential area is likely to cause harmful interference in which case the user will be required to correct the interference at his own expense.

INSTALLER:

SEE UNIT LABEL FOR ADDITIONAL MODEL SPECIFICATIONS
SAVE THESE INSTRUCTIONS FOR USE BY OWNER/OCCUPANT



CAUTION: DISCONNECT POWER DURING INSTALLATION AND BEFORE SERVICING.
READ ALL INSTRUCTIONS COMPLETELY BEFORE STARTING INSTALLATION.



INSTALLATION

CAUTION: SUPPLY AC POWER TO THE EMERGENCY DRIVER BEFORE JOINING BOTH CONVERTER CONNECTOR RED WIRES

This product is suitable for field installation with suitable LED loads including LED luminaires, DC voltage driven LED replacements for fluorescent lamps and others. There are 4 checks to determine if your luminaire is eligible for field installation.

1. Ensure the LED load's rated power is greater than or equal to the power output of this emergency LED driver (7W). This is to ensure that this emergency product will not produce more power than the LED load can handle, thus ensuring that the LED load will not be damaged when the system is in the emergency mode.
2. Verify the forward voltage of the luminaire's LED array is within the limits of this emergency LED driver. The forward voltage of the LED array is commonly designated as V_f and should be found on the luminaire markings, in the luminaire specifications, or imprinted directly on the LED arrays. If multiple LED arrays are to be driven, verify that the total forward voltage is within the limits of this product. Using a voltage meter, it may be possible to directly measure the voltage across the LED array when operating from the AC driver.
3. Ensure the output current of the LED driver does not exceed 1.6 Amps. This is the current into the blue wire.
4. Ensure the LED fixture's rated efficacy is equal to or greater than 65 lm / watt. This is to ensure that the LED fixture can be mounted at or below the maximum rated mounting height of 25.8 ft.
5. Ensure there will be sufficient light output in the end application. Estimate the emergency egress lighting illumination levels by doing the following.

You can estimate the egress lighting illumination levels by doing the following:

- a. Find the efficacy of the LED lighting fixture. Luminaire efficacy information can be found at the Design Lights Consortium website (<http://www.designlights.org>), Energy Star - Certified Products - product finder website (<http://www.energystar.gov/productfinder/>) or given by the luminaire manufacturer on product catalog specification sheets. The LED fixture efficacy will be given in lumens per watt (lm/w).
- b. Lumens can be calculated by multiplying the output power of the emergency LED driver (7W) by the efficacy of the LED load.
In many cases the actual lumen output in emergency mode will be greater than this calculation gives, however it will provide a good estimate for beginning the lighting design of the system.

$$\text{Lumens In Emergency Mode} = \text{Lumens Per Watt of Fixture} * \text{Output Power of Chosen Product}$$

$$(\text{LUMENS}) = (\text{LM/W}) * \text{W}$$

- c. Using the results of this calculation and industry standard lighting design tools, calculate the anticipated illumination levels in the path of egress.

NOTE: This product has been designed to reliably interface with a wide selection of LED loads and is electrically compatible with every simple LED array that meets criteria 1 - 4 above. However, compatibility cannot be guaranteed with all current and future LED systems. Compatibility testing of the end-use system is suggested. Please contact the factory with any questions.

NOTE: After installation, it will be necessary to measure the egress lighting illumination levels to ensure it complies with national, state, and local code requirements.

Installation of this Emergency LED Driver will vary based on the luminaire type, however, generally follow these steps.

- Step 1. Disconnect AC power to the LED lighting fixture. Remove lens and ballast channel cover from LED fixture if applicable. (see illustrations 2 & 4)
- Step 2. Using the 2 supplied screws, mount the LED emergency driver. The lighting fixture instructions might provide suggestions on the driver mounting location.
- Step 3. Test switch/indicator light can be mounted directly to a fixture surface thru a 1/2 inch diameter hole. Once nut is tightened, slip UL switch cover over wires, pushing cover against fixture surface completely covering switch, then affix ty-wrap over wires against cover to secure. Switch should be visible once fixture is installed. (see illustration 1 & 4)
- Step 4. Test switch/indicator light can also be installed onto a driver channel cover through a 7/8 inch diameter hole (see illustrations 2 & 3.) Trim plastic tube to desired length, affix UL switch cover as shown and place into tube. Affix both the small bushing and the large bushing onto the plastic tube as shown. Connect tie wrap onto wires, tighten and insert into channel. Switch should be visible once fixture is installed.

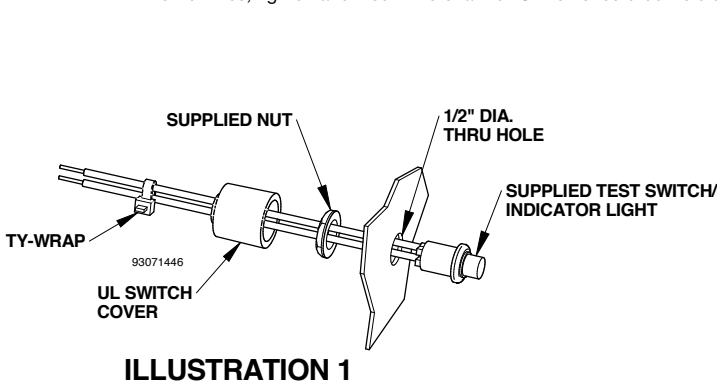

ILLUSTRATION 1

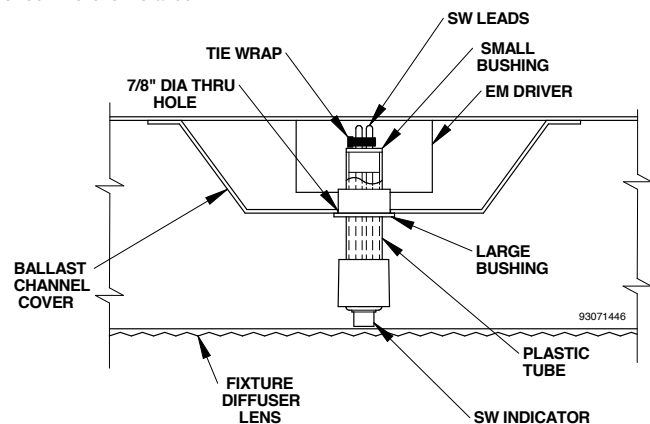

ILLUSTRATION 2

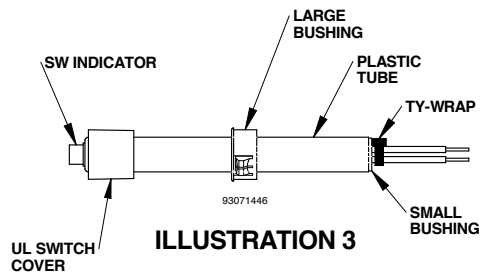

ILLUSTRATION 3

Mounting Height: This product meets or exceeds the NFPA minimum light requirements with all loads, down to the smallest rated lamp load, at heights up to 25.8ft (7.8m). Many factors influence emergency illumination levels, such as the lamp load selected, luminaire design, and environmental factors, therefore end use verification is necessary. For field installations, when the attached luminaire is mounted at heights greater than 25.8ft (7.8m), the level of illumination must be measured in the end application to ensure the requirements of NFPA 101 and local codes are satisfied.

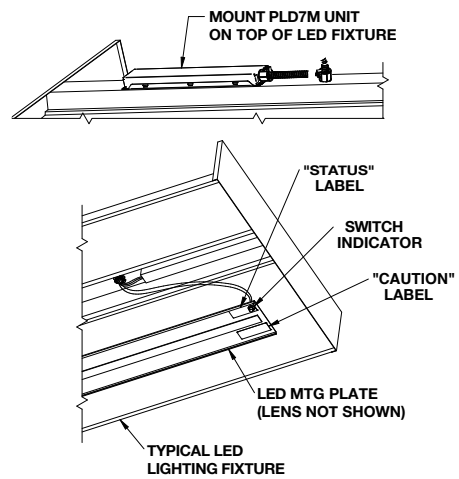

ILLUSTRATION 4

- Step 5. Select correct wiring diagram to connect the emergency driver to the LED load, AC LED driver and Switch. Make sure all connections are in accordance with the National Electrical Code and any local regulations.
- Step 6. Install in a visible location the labels "CAUTION" & "STATUS" (see illustration 4).
- Step 7. After installation is complete, supply AC power to the emergency ballast and join the converter battery connector.
- Step 8. At this point, power should be connected to both the AC driver and the emergency driver, and the charging indicator light should illuminate indicating the battery is charging.
- Step 9. A short-term discharge test may be conducted after the emergency ballast has been charging for one hour.
- Step 10. Charge for 24 hours before conducting a long-term discharge test. Refer to "Operation" section below

WIRING

Note: Make sure the necessary branch circuit wiring is available. An unswitched source of power is required. The emergency ballast must be fed from the same branch circuit as the AC ballast.

**EMERGENCY DRIVER AND AC DRIVER MUST BE FED FROM THE SAME BRANCH CIRCUIT
TYPICAL SCHEMATICS ONLY. CONSULT THE FACTORY FOR OTHER WIRING DIAGRAMS**

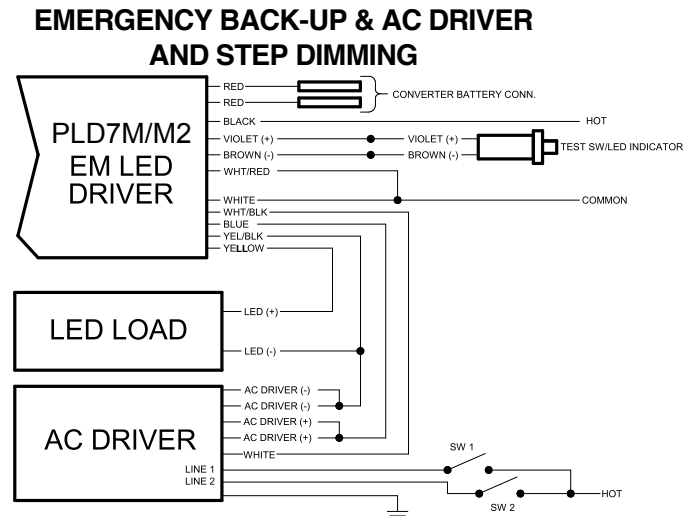
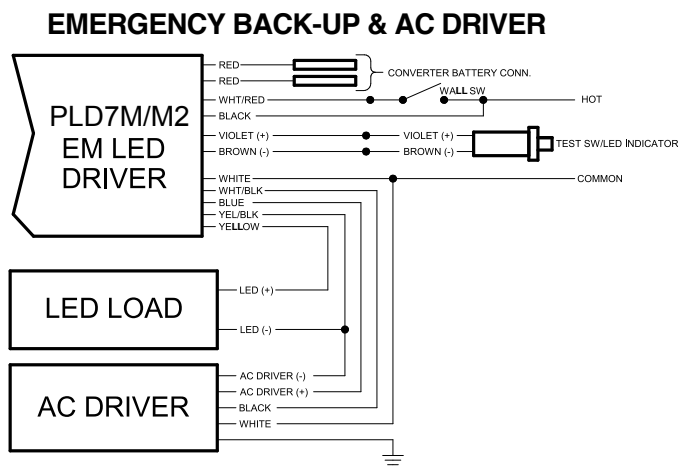

EMERGENCY BACK-UP ONLY

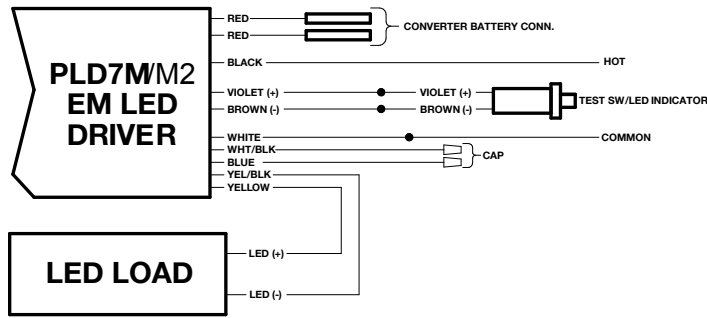

GROUND WIRE INSTALLATION

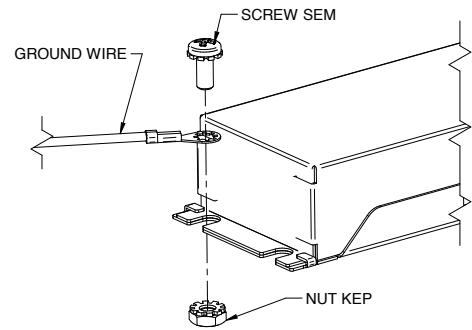

NOTE: For short term testing of the emergency function, the battery must be charged for at least one hour. The emergency driver must be charged for at least 24 hours before conducting a long term test.

OPERATION

During normal operation AC power is applied, the charging red indicator light is illuminated, indicating that the battery is being charged. When power fails, the emergency LED driver automatically switches to emergency power (internal battery), operating the LED load for a minimum of 90 minutes. When AC power is restored, the emergency driver returns to the charging mode (red LED on). The unit also has a visual indication of unit malfunction when there is a "Charger Fault" with the red LED blinking three times with a 3 second pause between the 3 blink group.

MAINTENANCE

Although no routine maintenance is required to keep the emergency driver functional, it should be checked periodically to ensure that it is working.

The following schedule is recommended:

1. Visually inspect the charging indicator light monthly. It should be illuminated.
2. Test the emergency operation of the fixture at 30-day intervals for a minimum of 30 seconds. Simply depress and hold the illuminated test switch. The LED load should operate at reduced illumination.
3. Conduct a 90-minute discharge test once a year, by turning off the AC circuit breaker at the service panel. The LED load should operate at reduced illumination for at least 90 minutes.

REFER ANY SERVICING INDICATED BY THESE CHECKS TO QUALIFIED PERSONNEL

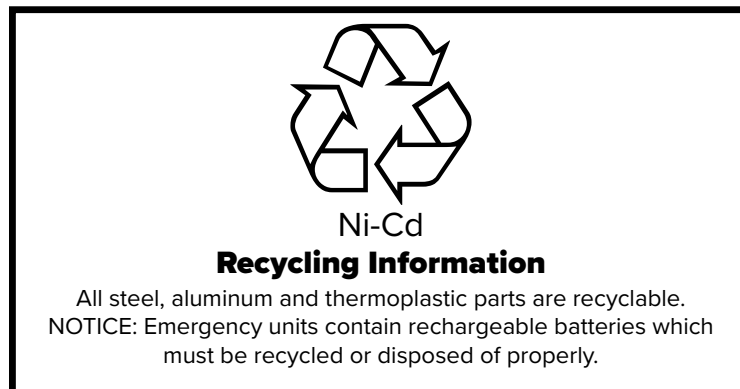

Hubbell Lighting, Inc. Life Safety Product • www.dual-lite.com

© 2020 Hubbell Lighting, Inc. • 701 Millennium Blvd • Greenville, SC 29607 • (864) 678-1000 • FAX(864) 678-1415 • www.dual-lite.com

93081726 G 10/20

